

## Dynamometer DYN 77



### **Dynamometer**

Dynamometer DYN 77 for deep well pump analyses. Diagrams can be recorded during the pumping cycle, without the need to stop the pump or to change the plunger setting-depth.

## Description

The DYN 77 has been developed after careful study of oilfield requirements and exhaustive practical tests over a period of years in varied and often difficult conditions, such as fast running, giant and multi-completion pumping installations.

This instrument records the polished rod load (instantaneous load) throughout the working cycle of a deep well pump. It provides accurate information about pump efficiency and the production that may be expected from it. It allows for recognizing the onset of pump failures, such as plunger or barrel wear and worn or sticking valves, prior to a production drop becoming apparent.

On the other hand, if production drops, a dynamometer log will provide evidence quickly to diagnose the fault. Regular, in some cases daily, dynamometer tests will draw attention to the inception of faults and thus reduce expensive servicing time and costly loss of production.

## What it does

Regular dynamometer logging of pump performance brings the following principal advantages:

- It provides, as outlined above, a permanent record of pump efficiency.
- It will reveal paraffin accumulation, damage to tubing and sucker rod string or stuffing box and polished rod. It will furnish data on which to base calculations of the depth of sucker rod failures. Leaking valves, tubing or pump barrel can be detected easily.
- A comparative study of dynamometer diagrams will indicate various changes of reservoir conditions such as gas or water encroachment. Regular dynamometer logging, without interruption of the pump, has the added advantage that changes in fluid level can be recognized.



## Where it works

### Spacers (Attachment Gears)

Each Pumping unit to be logged must be equipped with a set of spacers (attachment gear) fitted to the polished rod above the hanger bar between the two wire lines.

Once fitted, the attachment gear remains as a permanent fixture to the pump and provides the unique advantage to instantly check the pump with the LEUTERT DYN 77.

Required minimum distance between the wire lines:

- 120 mm / 4-3/4" for DYN 77.0
- 140 mm / 5-1/2" for DYN 77.1
- 190 mm / 7-1/2" for DYN 77.2
- 250 mm / 9-5/8" for DYN 77.3

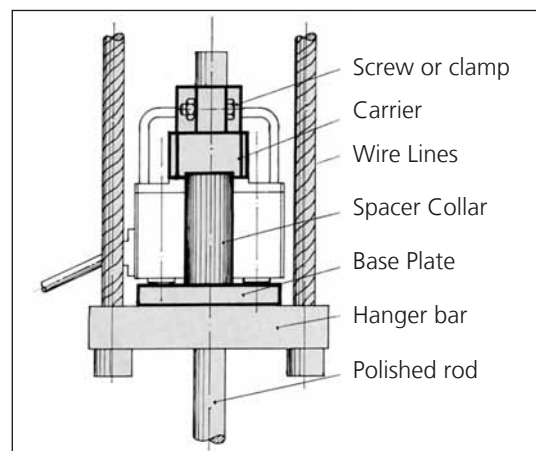

*Installation of the spacers*

### Why choose a LEUTERT Dynamometer

Dynamometer logging only achieves maximum significance, if the instrument can be fitted quickly without interruption of the pumping process or change of the plunger setting-depth. Its installation is so simple that it can be fitted without special training by any field operator. In contrast to other dynamometers in the market, the Dynamometer DYN 77 fits these basic requirements ideally, because it may be fitted to the traveling polished rod and registers the actual cyclic fluctuations of pump loading within minutes without disturbance of subsurface conditions.

### How it works

The polished rod load acts on two jacks (J) and generates hydraulic pressure ( $P_i$ ) inside the Dynamometer body. The pressure is transferred to the indicator (I). Therein the pressure works on the area of a piston ( $A_i$ ) which is counter-loaded by a precisely calibrated spring. Each indicator is equipped with four interchangeable measuring springs, allowing adjustment of the system to the actual load range of the pump up to maximum load of the respective Dynamometer. The stylus producing the graph is attached to the piston of the indicator. A special gear assures that the stylus point always travels perpendicularly to the base line of the Dynamometer chart. In summary, the simple working principle of DYN 77 provides two major advantages:

- Reliable performance for many years with minimum maintenance, re-calibration and overhaul.
- The interchangeable spring of the indicator assures the optimum utilization of the chart space in order to obtain a maximum resolution of the graph, essential for easy and exact evaluation.

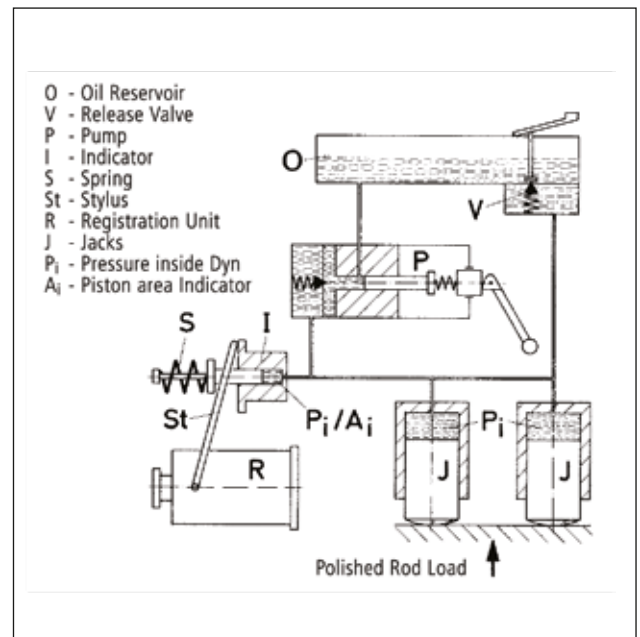

Specification of available types:

Type	Max. Load			for Polished Rod Diameter		
	kN	tons	lbs	1-1/8"	1-1/4"	1-1/2"
<b>DYN 77.0</b>	45	4.5	10,000	x	x	
<b>DYN 77.1</b>	75	7.5	16,500	x	x	
<b>DYN 77.2</b>	140	14.0	31,000		x	x
<b>DYN 77.3</b>	220	22.0	48,500		x	x

Selectable max. load within the loadrange of each Dynamometer, A = in kN (tons) , B = in 1000 lbs  
Four interchangeable springs are furnished with each instrument.

Spring	I		II		III		IV	
	A	B	A	B	A	B	A	B
<b>DYN 77.0</b>	21 (2.1)	4.5	28 (2.8)	6.0	36 (3.6)	8.0	45 (4.5)	10.0
<b>DYN 77.1</b>	36 (3.6)	8.0	48 (4.8)	10.5	60 (6.0)	13.0	75 (7.5)	16.5
<b>DYN 77.2</b>	67 (6.7)	14.0	89 (8.9)	19.5	102 (10.2)	24.5	140 (14.0)	31.0
<b>DYN 77.3</b>	105 (10.5)	22.0	140 (14.0)	31.0	176 (17.6)	38.5	220 (22.0)	48.5

## Registration Unit

The Registration System of the LEUTERT DYN 77 is designed for simplicity and accuracy. The linear polished rod motion is changed into rotating motion by a special reducer gear on which the chart drum is mounted. There are seven types of Registration Units to accommodate any maximum stroke length, all of which are interchangeable on any type of LEUTERT Dynamometers.

max. stroke length	Registration Unit type
1.00 m / 39"	6
2.00 m / 78"	11
3.50 m / 138"	19
4.00 m / 156"	22
5.00 m / 197"	28
6.10 m / 240"	34
8.00 m / 315"	44



## The result

A complete pump test including valve checks and counterbalance effect on a chart made by LEUTERT DYN 77.

**Base line:** Essential for instant read-out of the actual load. For the four springs there are corresponding read-off scales available.

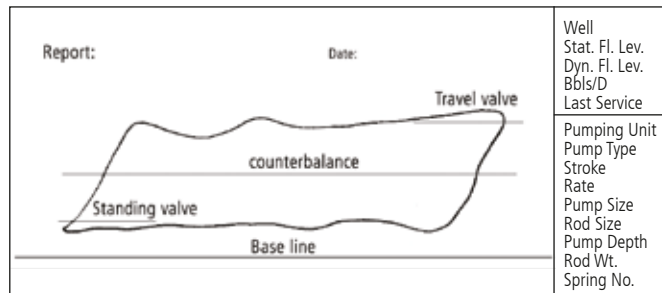

Outline dimensions:

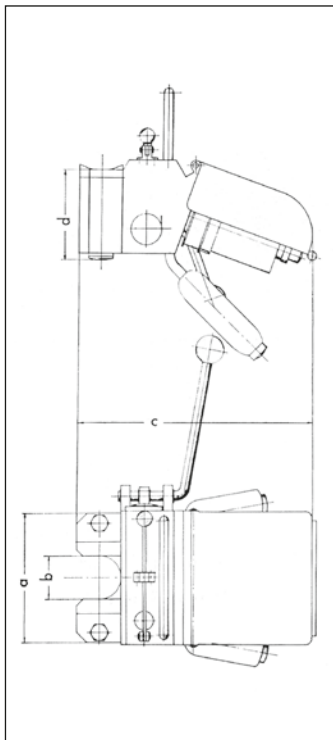

Model number	DYN 77.0	DYN 77.1	DYN 77.2	DYN 77.3	
Dimensions in mm Inches	a	115 mm 4.527"	135 mm 5.315"	184 mm 7.244"	237 mm 9.3"
	b	45 mm 1.772"	45 mm 1.772"	52 mm 2.047"	68 mm 2.7"
	c	275 mm 9.764"	275 mm 9.764"	291 mm 10.866"	338 mm 13.3"
	d	92 mm 3.700"	95 mm 3.700"	110 mm 4.300"	151 mm 5.9"
Net Weight of Instrument without Accessories	7 kg 15.5 lbs	7.2 kg 15.6 lbs	9,1 kg 20.2 lbs	13.5 kg 30 lbs	

Polished rod diameter	Dynamometer Type used	Size of Spacers to be used
1-1/8"	DYN 77.0	DYA 76.1
1-1/8"	DYN 77.1	DYA 76.2
1-1/4"	DYN 77.0	DYA 76.3
1-1/4"	DYN 77.1	DYA 76.4
1-1/4"	DYN 77.2	DYA 76.5
1-1/4"	DYN 77.3	DYA 76.6
1-1/2"	DYN 77.2	DYA 76.7
1-1/2"	DYN 77.3	DYA 76.8