

Accessories for Downhole Gauges: **1.68" Roller Centralizer**

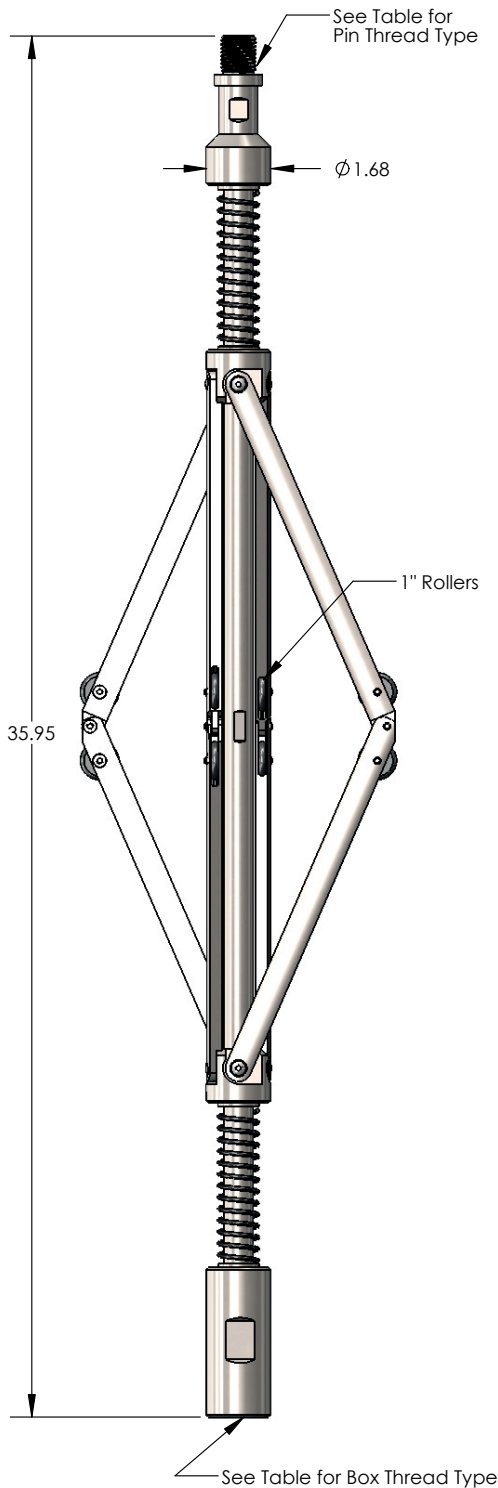

Features

- ✦ Use to Centralize Memory Tools in Tubing or Casing
- ✦ 4 Arm Design Evenly Distributes Loading
- ✦ For Use with Memory Tools up to 200°C and 30,000 PSI
- ✦ NACE Compliant Construction for Sour Service
- ✦ Available with Either *Amerada* or *Sucker Rod* Threads
- ✦ Bidirectional Breakaway

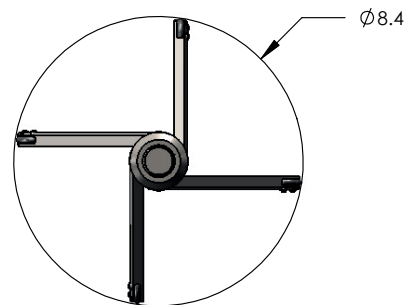

Fully Opened

1.68" OD Roller Centralizer		
Assembly Type	Thread Type	Part No.
Sweet Version (SS 17-4)	Amerada	104205
	5/8" SR	104078
Sour Version (Inconel 718)	Amerada	103515
	5/8" SR	104206

Specifications	
OD	1.687" Max
Overall Length	36"
Make Up Length	35"
Centralizing Range	1.7" to 8.4"
Break Direction	Up or Down
Centralizing Load Capacity	35 lbs
Tensile Breaking Strength	30,000 lbs Min
Working Load	10,000 lbs

Replacement Parts	Part No.
Centralizer Upper Arm - Stainless Steel	104460
Centralizer Upper Arm - CRA	103521
Centralizer Lower Arm - Stainless Steel	104461
Centralizer Lower Arm - CRA	103522
Arm Retention Screw - 1/4"-20 Button Head - Stainless	104090
Set Screw - #10-32 x .375 - Stainless	104143
Roller Screw - #10-32 x .44" Countersink	104088
1.0" Roller	104085
Roller Bushing - Brass	104089
Roller Bushing - Hardened	104215
Centralizer Spring - Standard	104081
Centralizer Spring - Reduced Rate	104638